

www.aggretech.co



Type
AGS0630M

DIESEL GENERATOR SET
Fuel Consumption Optimized
600/660 kVA

Machine Set

Diesel Generating Set

Type AGS0630M

600/660 kVA

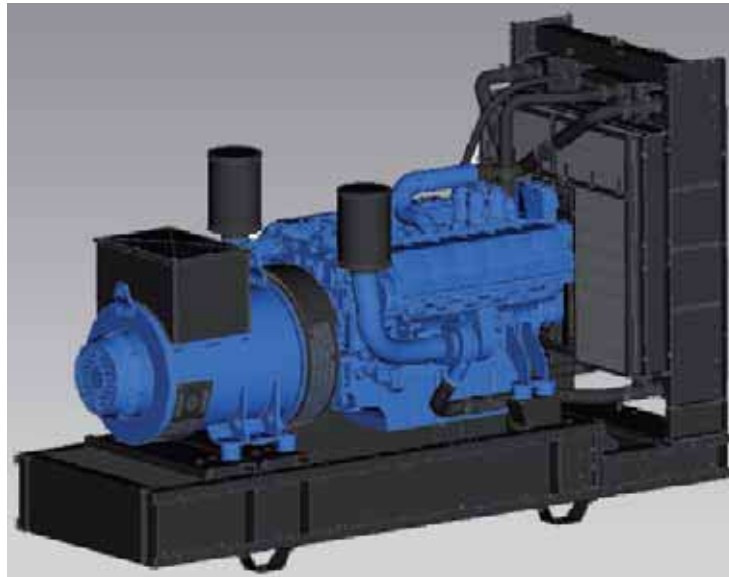

Torsion-free base frame made of laser-cut, welded tilted steel profiles; machine group is mounted on base frame with rubber feet which allow the machine group to vibrate; however, there is no transfer of vibration to frame; eyelets for crane hooks included in base frame; engine and alternator are connected with steel flange coupling;

Genset Data

Prime power (PRP)	600 kVA
Emergency power (ETP)	660 kVA
Power factor (cos phi)	0.8
Nominal voltage	400 V / 230 V
Nominal current	867 A
Frequency	50 Hz
Speed	1 500 min
Load acceptance	approx. 60 %

Fuel System[†]

Fuel consumption at		
	100 % load	120.5 l/h
	75 % load	93.7 l/h
	50 % load	65.0 l/h
	25 % load	35.6 l/h
Fuel consumption at		
	100 % load	192 g/kWh
	75 % load	199 g/kWh
	50 % load	207 g/kWh
	25 % load	227 g/kWh
Fuel tank capacity (Open Set)		400 l
Fuel tank capacity (Sound Proof)		1 400 l
Autonomy at full load (Open Set)		3.3 h
Autonomy at full load (Sound Proof)		11.6 h

Dimensions and Weights

Open Set	
Length	3 470 mm
Width	1 341 mm
Height	2 219 mm
Weight	4 350 kg
Sound Proof	
Length	5 182 mm
Width	1 780 mm
Height	2 602 mm
Weight	6 650 kg

Noise Emission⁵

Sound pressure _{PA} @ 1m (Open Set)	102 dB(A)
Sound pressure _{PA} @ 7m (Sound Proof)	approx. 70 dB(A)

Engine Data

Manufacturer	MTU
Type	12V 1600 G10F
Configuration	4 cycle; V; 12 cylinder Diesel
Aspiration	turbo charged with charge air cooler
Displacement	21.0 l
Gross output - Prime power (PRP)	524.0 kW
Gross output - Emergency power (LTP)	576.0 kW
Compression ratio	17.5:1
Governor type	electronic
Oil capacity (sump)	64 l
Oil consumption	< 0.5 % of fuel consumption
Starting voltage	24 V
Exhaust emission standard	TA Luft 4000 (Edition 1986)

Combustion Air

Combustion air volume	2 160 m ³ /h
Air cleaner type	dry; replaceable element with safety cartridge

Exhaust System

Max. exhaust gas temperature	482 °C
Max. exhaust back pressure	150 mbar
Exhaust gas flow	5 400 m ³ /h

Heat Rejection

Heat rejection to coolant	231.0 kW
Heat rejection to charge air cooler	87.0 kW
Heat rejection to engine radiation and convection	25.0 kW
Heat rejection to alternator radiation and convection	30.9 kW

Legend:

¹PRP (Prime Power) is available at a variable load for unlimited hours. Adjustable permanent output 100 %, no time restrictions. Prime Power is in accordance with ISO 8528. A 10 % overload capacity is available for limited time in accordance with ISO 3046, AS 2789, DIN 6271 and BS 5514.

²LTP (Limited Time Power) is applicable for supplying power to a constant electrical load for limited hours in the event of a main power network failure. No overload is permitted. LTP is in accordance with ISO 8528.

³max. additional output in kVA (PRP).

⁴Fuel consumption according to MTU datasheet.

⁵at 75 % load, according to EU directive 2000/14/EG

Alternator Data

Manufacturer	Aggretech
Type	ACG0630-4-400
Mechanical protection (IP class)	IP 23
Insulation class	H
Excitation	brushless, self-exciting synchronous alternator
Voltage control	electronic, self-regulating +/- 1 %
Short circuit capability	3x nominal current
AC wavefactor total harmonic distortion	< 2 %
Radio interference	EN 55011 Class B, Group 1
Efficiency (cos phi 0,8 / 400V) at	
100 % load	94.2 %
75 % load	94.2 %
50 % load	93.8 %
Cooling air volume	4 134 m ³ /h

Cooling System

Standard of cooling system	water cooled
Fan power consumption	18.0 kW
Cooling air flow	40 320 m ³ /h
Coolant temperature (at engine outlet in front of cooling equipment)	95 °C
Max. coolant temperature after engine (Alarm)	105 °C
Max. coolant temperature after engine (Shutdown)	105 °C
Coolant flow rate	26 m ³ /h
Inlet pressure of cooling pump min./ max.	3.5 bar
Max. pressure in cooling system	5.0 bar
Max. pressure loss in external cooling system	1.0 bar

Quality standards:

VDE 0530, DIN 6280, ISO 8528, IEC 34, BS 4999, BS 5000, BS 5514; We are certified specialist according to §19 I WHG.

All performance figures are to be understood for ambient conditions as follows: ambient temperature 25 °C, 100 m above sea level, rel. humidity 30 %. We reserve the right to change specifications without notice.

Diesel Generating Set Type AGS0630M 600/660 kVA

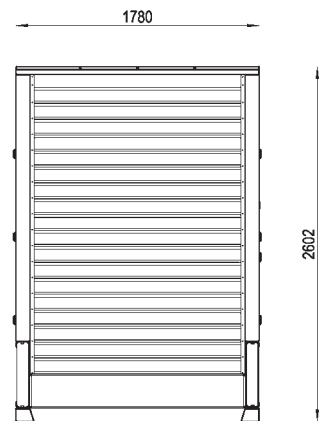
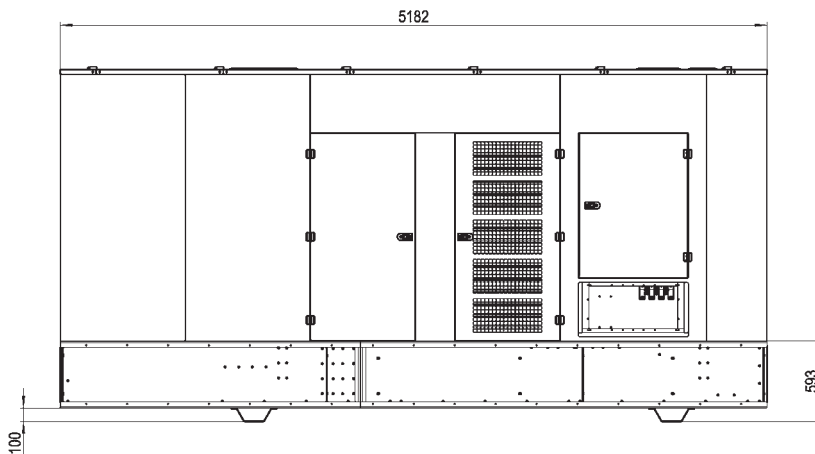
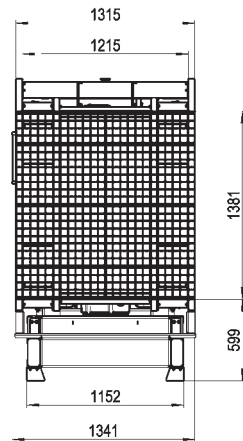
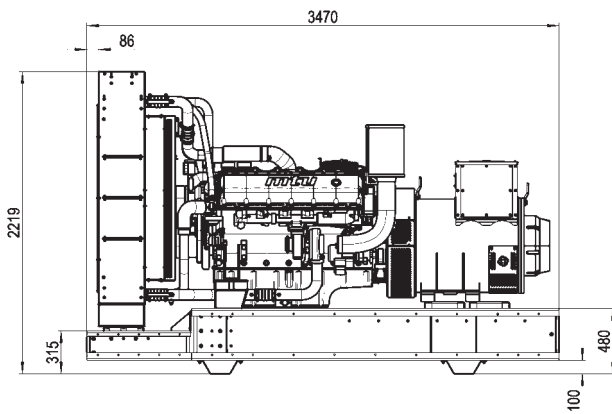

Your authorised dealer

Drawings are not true to scale.

Weights refer to the dry weights and represent a set with standard features. Accessories and loose parts are not accounted. Drawings are for illustrative purposes only and might include special accessories.

We reserve the right to change specifications without notice.

A 3 / AGS0630M – 01/07/2010 – E

Electromech Engineering Ltd.
Electromech House
Unit 7 Otterswood Square
Martland Mill Industrial Estate
WIGAN
Lancashire
WN5 0LF

Telephone: 01942 226322
Fax: 01942 226307
email: sales@electromech.org

